

### ENGINE

Model	Case Family IV, 445TA/EGE, Tier III certified
Type	4-stroke, turbocharged and air to air cooled
Cylinders	4
Bore/Stroke	4.09 in x 5.20 in (104 X 132 mm)
Displacement	274 in <sup>3</sup> (4.5 L)
Fuel injection	Electronic
Fuel	#2 Diesel
Fuel filter	Replaceable, full flow spin-on cartridge
Air filter	Dry type element w/warning restriction indicator
Mid-mount cooling module	External independent mounted coolers
Fan	
Style	8 blade puller
Diameter	32 in (813 mm)
Water pump	
Style	Integral
Engine oil	
Pump operating angle ratings	
Side-to-side	Rated 35°
Fore and aft	Rated 35°
Oil filtration	Replaceable, full flow spin-on cartridge
Horsepower – Peak	
Max Power	
Gross	142 (106 kW) @ 1800 rpm
Net	131 (98 kW) @ 1800 rpm
Standard Power	
Gross	129 (96 kW) @ 1800 rpm
Net	118 (88 kW) @ 1800 rpm
Economy Power	
Gross	110 (82 kW) @ 1700 rpm
Net	101 (75 kW) @ 1700 rpm
Torque – Peak	
Max Power	
Gross	448 lb-ft (608 N·m) @ 1600 rpm
Net	424 lb-ft (575 N·m) @ 1600 rpm
Standard Power	
Gross	407 lb-ft (552 N·m) @ 1300 rpm
Net	391 lb-ft (530 N·m) @ 1300 rpm
Economy Power	
Gross	403 lb-ft (547 N·m) @ 1200 rpm
Net	389 lb-ft (528 N·m) @ 1200 rpm
Torque rise	19%

NOTE: Gross horsepower and torque per SAE J1995.  
Net horsepower and torque per SAE J1349.

### DRIVETRAIN

Transmission	4F/3R Proportional w/Electronic Control Module torque sensing autoshift/manual shift and modulation	
Gears	Helical cut	
Gear ratios	Forward	Reverse
1st	4.012	3.804
2nd	2.174	2.061
3rd	1.088	1.031
4th	0.619	NA
Torque converter		
Stall ratio	2.30:1	
Differential	Limited slip w/45% transfer on front and rear axles	
Front and rear axle		
Differential ratio	3.36	
Planetary ratio	6.40	
Final axle ratio	21.53	
Planetaries	Outboard	
Service brakes	Hydraulically actuated, maintenance-free, multiple wet disc w/accumulator to all four wheels	
Brake surface area	480 in <sup>2</sup> per hub (0.309 m <sup>2</sup> )	
Parking brakes	Spring-applied hydraulic release disc on transmission output shaft	
Travel speeds – mph (km/h) w/17.5 x 25 L3 tires	Forward	Reverse
1st	3.8 (6.1)	4.0 (6.4)
2nd	6.9 (11.1)	7.3 (11.7)
3rd	13.4 (21.6)	14.1 (22.8)
4th	22.3 (35.9)	NA

NOTE: Travel speeds at full engine throttle.

### ELECTRICAL

Voltage	24 Volts, negative ground
Alternator	70 amp
Batteries	(2) 12 Volt

### HYDRAULICS

Pump (steering/implement)	Closed centered pressure/flow compensated
Variable displacement	4.33 in <sup>3</sup> /rev 35.4 gpm @ 2000 rpm @ 2750 psi (134 L/min @ 2000 rpm @ 18 961 kPa)
Loader control valve	Closed-center, sectional 2, 3 or 4-spool with pilot control for lift, tilt and auxiliary hydraulics, electromagnetic detents in float, raise and rollback
Loader auxiliary steering	Hydraulic orbital center-pivot articulating w/on-demand oil flow
High pressure standby	3625 psi (25 000 kPa)
Filtration	10-micron, full flow replaceable cartridges on return line, condition indicator light for filter

### CYLINDERS

Lift cylinder	
Bore diameter	4.0 in (102 mm)
Rod diameter	2.25 in (57 mm)
Stroke	30.82 in (783 mm)
Dump cylinder (Z-Bar and XR)	
Bore diameter	4.5 in (114 mm)
Rod diameter	2.5 in (64 mm)
Stroke	20.84 in (529 mm)
Dump cylinders (XT)	
Bore diameter	3.75 in (95.2 mm)
Rod diameter	2.25 in (57 mm)
Stroke	36.32 in (922.4 mm)

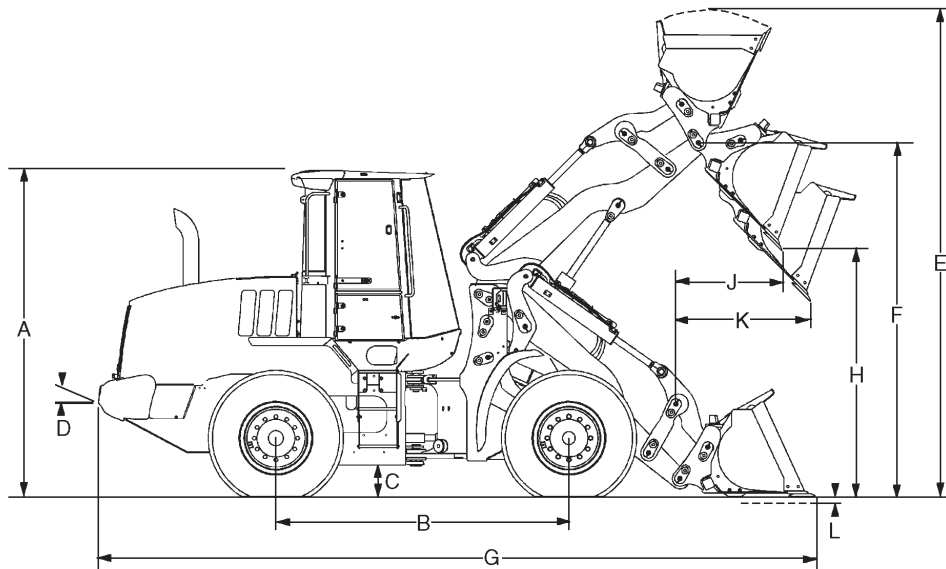

## DIMENSIONS

Height to –		
<b>A.</b>	Top of ROPS cab	129.0 in (3277 mm)
	Drawbar	37.6 in (954 mm)
<b>B.</b>	Wheelbase	108.3 in (2750 mm)
<b>C.</b>	Ground clearance	14.9 in (377 mm)
<b>D.</b>	Angle of departure	34°
Width –		
	Overall* w/o bucket	98.0 in (2489 mm)
	Centerline tread	78.7 in (2000 mm)
	Turning radius* – outside	195.8 in (4972 mm)
Turning angle –		
	From center	40°
	Total angle	80°
	Rear axle oscillation, total	24°

NOTE: \*Dimensions taken with 17.5x25 XTLA TL tires. Additional dimensions on pages 3 & 4.

## WEIGHT ADJUSTMENTS

Select Options	Weight Adjustment	Tipping Load Adjustment Straight	Tipping Load Adjustment 40° Turn
17.5x25 12 ply L2 tires	-408 lb (-185 kg)	-298 lb (-135 kg)	-263 lb (-120 kg)
17.5x25 12 ply L3 tires	-200 lb (-91 kg)	-146 lb (-66 kg)	-129 lb (-59 kg)
17.5-R25 XHA TL tires	+224 lb (+101 kg)	+163 lb (+74 kg)	+144 lb (+65 kg)
20.5 R25 XHA TL	+663 lb (+301 kg)	+482 lb (+219 kg)	+426 lb (+193 kg)
Base counterweight	-1,050 lb (+301 kg)	-2,370 lb (-1075 kg)	-1,995 lb (-905 kg)
Open ROPS	-295 lb (-134 kg)	-299 lb (-136 kg)	-276 lb (-125 kg)

NOTE: \*\*Unit equipped with Z-Bar loader arms, 2.1 yd<sup>3</sup> (1.61 m<sup>3</sup>) general purpose pin on bucket w/bolt-on edge, 17.5-R25 XTLA Michelin tires, ROPS cab with heater and A/C, full counterweight, standard batteries, front and rear fenders, full fuel and 175 lb (79 kg) operator. Adjust select options from rated weight.

**PERFORMANCE DATA**

<b>521E Z-Bar*</b>	<b>2.6 yd<sup>3</sup> GP (1.99 m<sup>3</sup>) Bucket w/Bolt-on Edge</b>	<b>2.3 yd<sup>3</sup> GP (1.76 m<sup>3</sup>) Bucket w/Bolt-on Edge</b>
SAE bucket capacity – struck	2.21 yd <sup>3</sup> (1.69 m <sup>3</sup> )	1.98 yd <sup>3</sup> (1.51 m <sup>3</sup> )
Heaped	2.6 yd <sup>3</sup> (1.99 m <sup>3</sup> )	2.3 yd <sup>3</sup> (1.76 m <sup>3</sup> )
Bucket width – outside	100.4 in (2550 mm)	100.4 in (2550 mm)
Bucket weight	1,619 lb (734 kg)	1,686 lb (765 kg)
<b>E.</b> Operating height – fully raised w/spillguard	186.8 in (4746 mm)	184.4 in (4684 mm)
<b>F.</b> Hinge pin height – fully raised	142.1 in (3608 mm)	142.1 in (3608 mm)
<b>G.</b> Overall length – bucket level on ground	265.9 in (6755 mm)	263.2 in (6685 mm)
Dump angle – fully raised	55°	55°
<b>H.</b> Dump height – fully raised, 45° dump	105.0 in (2667 mm)	106.6 in (2708 mm)
<b>J.</b> Bucket reach – fully raised, 45° dump	41.6 in (1056 mm)	39.9 in (1013 mm)
<b>K.</b> Bucket reach – 7 ft 0 in (2.13 m) height, 45° dump	57.6 in (1463 mm)	56.9 in (1444 mm)
Operating load – ISO	7,969 lb (3615 kg)	8,006 lb (3631 kg)
Maximum material density – ISO	3,065 lb/yd <sup>3</sup> (1819 kg/m <sup>3</sup> )	3,481 lb/yd <sup>3</sup> (2065 kg/m <sup>3</sup> )
Tipping load – ISO		
Straight	18,291 lb (8297 kg)	18,381 lb (8337 kg)
40° turn	15,939 lb (7230 kg)	16,011 lb (7262 kg)
Lift capacity –		
Full height	12,338 lb (5596 kg)	12,272 lb (5567 kg)
Maximum reach	17,009 lb (7715 kg)	16,956 lb (7691 kg)
Ground	21,121 lb (9580 kg)	22,328 lb (10 128 kg)
Breakout force w/tilt cylinder	18,175 lb (8244 kg)	19,364 lb (8784 kg)
Maximum rollback –		
@ Ground	40°	40°
@ Carry position	43°	43°
@ Maximum reach	52°	52°
@ Full height	54°	54°
<b>L.</b> Dig depth	3.1 in (78 mm)	2.8 in (70 mm)
Maximum grading angle w/bucket – back dragging	60°	60°
Loader clearance circle	434.3 in (11 032 mm)	432.7 in (10 991 mm)

<b>521E XT</b>	<b>2.1 yd<sup>3</sup> GP (1.61 m<sup>3</sup>) ACS Bucket w/Edge**</b>	<b>2.1 yd<sup>3</sup> GP (1.61 m<sup>3</sup>) ACS Bucket w/Teeth and Segment**</b>
<b>E.</b> Operating height – fully raised w/spillguard	197.6 in (5020 mm)	197.6 in (5020 mm)
<b>F.</b> Hinge pin height – fully raised	147.4 in (3743 mm)	147.3 in (3742 mm)
<b>G.</b> Overall length – bucket level on ground	261.9 in (6652 mm)	261.9 in (6652 mm)
Dump angle – fully raised	57°	57°
<b>H.</b> Dump height – fully raised, 45° dump	109.4 in (2780 mm)	109.4 in (2780 mm)
<b>J.</b> Bucket reach – fully raised, 45° dump	43.9 in (1116 mm)	43.9 in (1116 mm)
<b>K.</b> Bucket reach – 7 ft 0 in (2.13 m) height, 45° dump	62.5 in (1587 mm)	62.5 in (1587 mm)
Operating load – ISO	6,648 lb (3016 kg)	6,441 lb (2922 kg)
Maximum material density – ISO	3,166 lb/yd <sup>3</sup> (1879 kg/m <sup>3</sup> )	3,067 lb/yd <sup>3</sup> (1820 kg/m <sup>3</sup> )
Tipping load – ISO		
Straight	15,640 lb (7094 kg)	15,223 lb (6905 kg)
40° turn	13,297 lb (6031 kg)	12,882 lb (5843 kg)
Lift capacity –		
Full height	10,617 lb (4816 kg)	10,216 lb (4634 kg)
Maximum reach	14,436 lb (6548 kg)	14,054 lb (6375 kg)
Ground	24,415 lb (11 074 kg)	24,067 lb (10 917 kg)
Breakout force – dump cylinder	22,290 lb (10 111 kg)	25,194 lb (11 428 kg)
Loader clearance circle	427.1 in (10 849 mm)	427.1 in (10 849 mm)

<b>521E XR</b>	<b>2.6 yd<sup>3</sup> GP (1.99 m<sup>3</sup>) Bucket w/Bolt-on Edge</b>	<b>2.3 yd<sup>3</sup> GP (1.76 m<sup>3</sup>) Bucket w/Bolt-on Edge</b>	<b>2.3 yd<sup>3</sup> GP (1.76 m<sup>3</sup>) Bucket w/Teeth &amp; Segments</b>
<b>E.</b> Operating height – fully raised w/spillguard	201.8 in (5125 mm)	199.3 in (5063 mm)	199.3 in (5063 mm)
<b>F.</b> Hinge pin height – fully raised	157.0 in (3987 mm)	157.0 in (3987 mm)	157.0 in (3987 mm)
<b>G.</b> Overall length – bucket level on ground	279.5 in (7100 mm)	276.8 in (7031 mm)	282.6 in (7178 mm)
Dump angle – fully raised	51°	51°	51°
<b>H.</b> Dump height – fully raised, 45° dump	119.9 in (3046 mm)	121.7 in (3092 mm)	117.9 in (2994 mm)
<b>J.</b> Bucket reach – fully raised, 45° dump	40.6 in (1032 mm)	38.9 in (988 mm)	42.9 in (1089 mm)
<b>K.</b> Bucket reach – 7 ft 0 in (2.13 m) height, 45° dump	69.4 in (1763 mm)	68.6 in (1742 mm)	70.7 in (1795 mm)
Operating load – ISO	6,747 lb (3060 kg)	6,767 lb (3069 kg)	6,696 lb (3037 kg)
Maximum material density – ISO	2,595 lb/yd <sup>3</sup> (1540 kg/m <sup>3</sup> )	2,942 lb/yd <sup>3</sup> (1746 kg/m <sup>3</sup> )	2,911 lb/yd <sup>3</sup> (1727 kg/m <sup>3</sup> )
Tipping load – ISO			
Straight	15,561 lb (7058 kg)	15,615 lb (7083 kg)	15,471 lb (7018 kg)
40° turn	13,493 lb (6120 kg)	13,534 lb (6139 kg)	13,392 lb (6074 kg)
Lift capacity –			
Full height	11,512 lb (5222 kg)	11,443 lb (5190 kg)	11,341 lb (5144 kg)
Maximum reach	15,104 lb (6851 kg)	15,050 lb (6827 kg)	14,943 lb (6778 kg)
Ground	19,067 lb (8649 kg)	19,101 lb (8664 kg)	18,982 lb (8610 kg)
Breakout force w/tilt cylinder	23,463 lb (10 642 kg)	19,366 lb (8784 kg)	19,257 lb (8735 kg)
Loader clearance circle	447.3 in (11 361 mm)	445.5 in (11 315 mm)	449.9 in (11 428 mm)

## PERFORMANCE DATA

<b>521E Z-Bar*</b>	<b>2.3 yd<sup>3</sup> GP (1.76 m<sup>3</sup>) Bucket w/Teeth &amp; Segments</b>	<b>2.1 yd<sup>3</sup> GP (1.61 m<sup>3</sup>) Bucket w/Bolt-on Edge</b>	<b>2.1 yd<sup>3</sup> GP (1.61 m<sup>3</sup>) Bucket w/Teeth &amp; Segments</b>
SAE bucket capacity – struck Heaped 2.3 yd <sup>3</sup> (1.76 m <sup>3</sup> )	1.98 yd <sup>3</sup> (1.51 m <sup>3</sup> ) 2.1 yd <sup>3</sup> (1.61 m <sup>3</sup> )	1.77 yd <sup>3</sup> (1.35 m <sup>3</sup> ) 2.1 yd <sup>3</sup> (1.61 m <sup>3</sup> )	1.77 yd <sup>3</sup> (1.35 m <sup>3</sup> )
Bucket width – outside	101.1 in (2567 mm)	100.4 in (2550 mm)	101.1 in (2567 mm)
Bucket weight	1,789 lb (811 kg)	1,599 lb (725 kg)	1,702 lb (772 kg)
<b>E.</b> Operating height – fully raised w/spillguard	184.4 in (4684 mm)	181.7 in (4616 mm)	181.7 in (4616 mm)
<b>F.</b> Hinge pin height – fully raised	142.0 in (3608 mm)	142.1 in (3608 mm)	142.0 in (3608 mm)
<b>G.</b> Overall length – bucket level on ground	269.0 in (6834 mm)	260.2 in (6609 mm)	266.1 in (6759 mm)
Dump angle – fully raised	55°	55°	55°
<b>H.</b> Dump height – fully raised, 45° dump	103.0 in (2615 mm)	108.8 in (2763 mm)	104.9 in (2665 mm)
<b>J.</b> Bucket reach – fully raised, 45° dump	43.8 in (1114 mm)	37.9 in (963 mm)	41.9 in (1064 mm)
<b>K.</b> Bucket reach – 7 ft 0 in (2.13 m) height, 45° dump	58.6 in (1490 mm)	55.9 in (1421 mm)	57.8 in (1469 mm)
Operating load – ISO	7,931 lb (3597 kg)	8,116 lb (3681 kg)	8,069 lb (3660 kg)
Maximum material density – ISO	3,448 lb/yd <sup>3</sup> (2046 kg/m <sup>3</sup> )	3,865 lb/yd <sup>3</sup> (2293 kg/m <sup>3</sup> )	3,842 lb/yd <sup>3</sup> (2280 kg/m <sup>3</sup> )
Tipping load – ISO			
Straight	18,229 lb (8268 kg)	18,620 lb (8446 kg)	18,532 lb (8406 kg)
40° turn	15,861 lb (7194 kg)	16,232 lb (7363 kg)	16,138 lb (7320 kg)
Lift capacity –			
Full height	12,169 lb (5520 kg)	12,360 lb (5607 kg)	12,257 lb (5560 kg)
Maximum reach	16,849 lb (7643 kg)	17,056 lb (7737 kg)	16,954 lb (7690 kg)
Ground	22,123 lb (10 035 kg)	23,872 lb (10 828 kg)	24,062 lb (10 914 kg)
Breakout force w/tilt cylinder	19,259 lb (8736 kg)	20,926 lb (9492 kg)	20,822 lb (9445 kg)
Maximum rollback –			
@ Ground	40°	40°	40°
@ Carry position	43°	43°	43°
@ Maximum reach	52°	52°	52°
@ Full height 54°	54°	54°	54°
<b>L.</b> Dig depth	3.2 in (80 mm)	2.5 in (64 mm)	2.9 in (75 mm)
Maximum grading angle w/bucket – back dragging	61°	60°	60°
Loader clearance circle	436.8 in (11 095 mm)	431.0 in (10 949 mm)	435.0 in (11 050 mm)

<b>521E XT</b>	<b>2.0 yd<sup>3</sup> GP (1.5 m<sup>3</sup>) Case Bucket w/Edge***</b>	<b>2.0 yd<sup>3</sup> GP (1.5 m<sup>3</sup>) Case Bucket w/Teeth***</b>
<b>E.</b> Operating height – fully raised w/spillguard	188.5 in (4787 mm)	188.5 in (4787 mm)
<b>F.</b> Hinge pin height – fully raised	147.4 in (3744 mm)	147.4 in (3744 mm)
<b>G.</b> Overall length – bucket level on ground	271.2 in (6889 mm)	277.1 in (7037 mm)
Dump angle – fully raised	57°	57°
<b>H.</b> Dump height – fully raised, 45° dump	102.0 in (2591 mm)	98.1 in (2493 mm)
<b>J.</b> Bucket reach – fully raised, 45° dump	40.6 in (1031 mm)	44.6 in (1132 mm)
<b>K.</b> Bucket reach – 7 ft 0 in (2.13 m) height, 45° dump	55.0 in (1397 mm)	56.4 in (1433 mm)
Operating load – ISO	6,473 lb (2936 kg)	6,414 lb (2909 kg)
Maximum material density – ISO	3,082 lb/yd <sup>3</sup> (1829 kg/m <sup>3</sup> )	3,054 lb/yd <sup>3</sup> (1812 kg/m <sup>3</sup> )
Tipping load – ISO		
Straight	15,138 lb (6867 kg)	15,021 lb (6813 kg)
40° turn	12,945 lb (5872 kg)	12,828 lb (5819 kg)
Lift capacity –		
Full height	10,944 lb (4964 kg)	10,832 lb (4913 kg)
Maximum reach	14,822 lb (6723 kg)	14,716 lb (6675 kg)
Ground	21,044 lb (9545 kg)	20,859 (9461 kg)
Breakout force – dump cylinder	21,650 lb (9820 kg)	21,549 lb (9775 kg)
Loader clearance circle	435.8 in (11 070 mm)	439.3 in (11 157 mm)

**NOTE:**

\*Z-Bar performance data shown w/full counterweight  
 \*\*XT lift arm with buckets for ACS Pro Series 2000® size 30 HD coupler.  
 \*\*\*XT lift arm with bucket for Case coupler

Performance data unit equipped with 17.5X25 XTLA tires, ROPS cab w/heater and A/C, full counterweight, standard batteries, front and rear fenders, full fuel and 175 lb (79 kg) operator. Specifications per SAE J732, J1234, J695, J742 and J818.

<b>521E XR</b>	<b>2.1 yd<sup>3</sup> GP (1.61 m<sup>3</sup>) Bucket w/Bolt-on Edge</b>	<b>2.1 yd<sup>3</sup> GP (1.61 m<sup>3</sup>) Bucket w/Teeth &amp; Segments</b>
<b>E.</b> Operating height – fully raised w/spillguard	196.6 in (4995 mm)	196.6 in (4995 mm)
<b>F.</b> Hinge pin height – fully raised	157.0 in (3987 mm)	157.0 in (3987 mm)
<b>G.</b> Overall length – bucket level on ground	273.9 in (6956 mm)	297.7 in (7104 mm)
Dump angle – fully raised	51°	51°
<b>H.</b> Dump height – fully raised, 45° dump	123.7 in (3142 mm)	119.8 in (3044 mm)
<b>J.</b> Bucket reach – fully raised, 45° dump	36.9 in (938 mm)	40.9 in (1039 mm)
<b>K.</b> Bucket reach – 7 ft 0 in (2.13 m) height, 45° dump	67.5 in (1715 mm)	69.7 in (1770 mm)
Operating load – ISO	6,862 lb (3112 kg)	6,811 lb (3090 kg)
Maximum material density – ISO	3,267 lb/yd <sup>3</sup> (1939 kg/m <sup>3</sup> )	3,244 lb/yd <sup>3</sup> (1925 kg/m <sup>3</sup> )
Tipping load – ISO		
Straight	15,819 lb (7175 kg)	15,723 lb (7132 kg)
40° turn	13,723 lb (6225 kg)	13,623 lb (6179 kg)
Lift capacity –		
Full height	11,527 lb (5228 kg)	11,424 lb (5182 kg)
Maximum reach	15,149 lb (6872 kg)	15,047 lb (6825 kg)
Ground	19,249 lb (8751 kg)	19,198 lb (8708 kg)
Breakout force w/tilt cylinder	20,932 lb (9494 kg)	20,823 lb (9445 kg)
Loader clearance circle	443.6 in (11 267 mm)	448.0 in (11 378 mm)

## INSTRUMENTATION

Electronic Information Center
Displays/Gauges –
Speedometer
Tachometer
Direction selected F/N/R
Transmission modes – Auto shift/Manual shift
Gear position
Engine coolant temperature
Fuel level
Transmission oil temperature
Hydraulic oil temperature
Hourmeter
Work mode
Indicator lights –
Low fuel
Turn signals
High beam lights
Grid heater*
Brake pressure
Master indicator
Secondary steering*
Parking brake
Audible alarms –
Caution alarm
Critical alarm
Backup alarm
Horn

NOTE: \*If equipped with option.

## OPERATOR ENVIRONMENT

ROPS cab w/ heat
Key start
Articulated power steering w/tilt column
Fully adjustable, suspension seat
Foot throttle
1-Lever loader control w/wrist rest
Cup holder
Coat hook
(1) Interior rearview mirror
2 in (51 mm) retractable seat belt
Storage tray behind seat
Cooled lunch box
Single brake pedal
F/N/R shuttle switch
External rear view mirrors
Lock box
Pressurized air filtering
Anti-glare window strip
Defroster
Side window, partial/fully open
Dome light
Wipers, rear and intermittent front
Windshield washers, front and rear
Rubber floor mat

## LOADER

Z-bar loader linkage
Single control for lift and tilt
Positive hold float
Automatic return-to-dig
Automatic height control
Automatic return-to-travel
Brake pedal transmission disconnect
Bucket position indicator on bucket

## CYCLE TIME

Raise w/rated bucket load	5.6 sec
Dump w/rated bucket load	
Z-Bar	1.1 sec
XT	1.1 sec
Lower (empty)	
Power down	3.7 sec
Float down	2.7 sec

## SERVICE CAPACITIES

Fuel tank	50 gal (189 L)
Hydraulic system	
Total	30 gal (114 L)
Reservoir	15 gal (57 L)
Transmission	
Service w/filter	5.0 gal (18.9 L)
Front and rear axle	
Front axle	22.7 qt (21.5 L)
Rear axle	22.7 qt (21.5 L)
Engine oil w/filter	3.3 gal (12 L)
Cooling system (-40)	5.8 qt (22 L)

## OPERATING WEIGHTS

### Z-Bar

Unit equipped with ROPS cab with heater and A/C, full counterweight, 17.5x25 XTLA Michelin tires, front and rear fenders, 2.1 yd<sup>3</sup> (1.61 m<sup>3</sup>) general purpose loader bucket w/edge, full fuel, 175 lb (79 kg) operator 23,069 lb (10 464 kg)

### XT

Unit equipped with ROPS cab with heater and A/C, full counterweight, 17.5 x 25 XTLA Michelin tires, 2.1 yd<sup>3</sup> (1.61 m<sup>3</sup>) ACS loader bucket, standard batteries, full fuel, 175 lb (79 kg) operator 26,861 lb (12 184 kg)

### XR

Unit equipped with ROPS cab with heater and A/C, full counterweight, 17.5x25 XTLA Michelin tires, front and rear fenders, 2.1 yd<sup>3</sup> (1.61 m<sup>3</sup>) general purpose loader bucket w/edge, full fuel, 175 lb (79 kg) operator 23,442 lb (10 633 kg)

## STANDARD EQUIPMENT

### OPERATOR'S ENVIRONMENT

See page 5

### ENGINE

Case Family IV 445TA/EGE  
Tier III certified  
Selectable work modes  
    Max power  
    Auto power  
    Standard power  
    Economy power  
Turbocharger  
Charge air cooling  
Automatic fan belt tensioner  
Integral engine oil cooling  
Fuel filter w/water trap  
Dual element air cleaner  
70 amp alternator  
(2) 700 CCA 12-volt batteries  
Liquid-cooled radiator  
Non spark-arresting muffler  
Mid-mounted cooling module  
Common rail electronic fuel injection

## OPTIONAL EQUIPMENT

### OPERATOR'S COMPARTMENT

Cloth-covered air-suspension seat  
Sound Shield noise suppression package  
Cab air-conditioning w/heater  
Radio  
Radio-ready (12 or 24-volt)  
Auxiliary power (12-volt)  
Cab convenience package  
RH steps and platform  
Rotating beacon  
Second brake pedal  
Open ROPS  
Joystick steering

### LOADER

See page 5

### DRIVETRAIN

4-wheel drive  
4F/3R Selectable autoshift/manual shift transmission  
Electronic Control Module – Programmable, computer controlled proportional shifting with programmable gear selection  
Onboard diagnostics  
Single lever electronic shift control  
F/N/R switch in loader control handle  
Downshift button  
Torque converter  
Outboard planetary axles  
Limited-slip differentials  
Transmission oil cooler  
Brake pedal transmission disconnect  
Hydraulic wet disc brakes  
Spring-applied hydraulic release parking brake  
Limp-Home Mode  
Lubed-for-life drive shaft

### ENGINE

Cold weather package  
    Heavy-duty batteries  
    Fuel heater  
    Hydraulic oil cooler bypass  
    Low temperature hydraulic oil  
    Grid heater

### LOADER

Hydraulic attachment coupler systems  
Attachment auxiliary hydraulics  
Buckets (see page 3 & 4)  
XT parallel lift  
XR extended reach

### HYDRAULICS

Auxiliary hydraulics  
Ride Control  
Secondary steering  
3 or 4-spool loader valves with 2 or 3-lever loader control  
Hydraulic reversing fan  
Hydraulic cooler

### HYDRAULICS

Single lever 2-spool loader control valve  
Low-effort steering  
Hydraulic driven fan  
(8) Diagnostic quick couplers

### OTHER

Front and rear fenders  
Lights –  
    (2) Front driving headlights (high/low beam)  
    (2) Front flood  
    (2) LED stop and tail lights  
    (2) Rear flood  
    Front and rear turn signal/flash  
Standard counterweight  
Drawbar hitch  
Articulation locking bar  
Lift arm locking bar  
Lift and tie-down points – front/rear  
Backup alarm  
Remote drain points

### TIRES

17.5 X 25 radial  
20.5 R25 radial  
20.5 R25 bias

### OTHER

Special paint  
Full coverage fenders  
Belly pan  
Tool box  
Full counterweight - Z-Bar  
Temperature controlled fan

NOTE: All specifications are stated in accordance with SAE Standards or Recommended Practices, where applicable.

NOTE: All engines meet current EPA emissions requirements.

IMPORTANT: Case Construction Equipment Inc. reserves the right to change these specifications without notice and without incurring any obligation relating to such change. Case Construction Equipment Inc. does not warrant the safety or reliability of attachments from other manufacturers.

Case is a registered trademark of CNH America LLC. Any trademarks referred to herein, in association with goods and/or services of companies other than CNH America LLC, are the property of those respective companies.