

ENGINE

Model	Case Family IV, 667TA/EDB, Tier III certified
Type	4-stroke, turbocharged and air to air cooled
Cylinders	6
Bore/Stroke	4.11 in x 5.20 in (104 X 132 mm)
Displacement	409 in ³ (6.7 L)
Fuel injection	Electronic
Fuel	#2 Diesel
Fuel filter	Replaceable, full flow spin-on cartridge
Air filter	Dry type element w/warning restriction indicator
Mid-mount cooling module	External independent mounted coolers
Fan	
Style	8 blade puller
Diameter	32 in (813 mm)
Water pump	
Style	Integral
Engine oil	
Pump operating angle ratings	
Side-to-side	Rated 35°
Fore and aft	Rated 35°
Oil filtration	Replaceable, full flow spin-on cartridge
Horsepower – Peak	
Max Power	
Gross	172 (128 kW) @ 1800 rpm
Net	162 (121 kW) @ 1800 rpm
Standard Power	
Gross	156 (116 kW) @ 1800 rpm
Net	146 (109 kW) @ 1800 rpm
Economy Power	
Gross	133 (99 kW) @ 1500 rpm
Net	125 (93 kW) @ 1500 rpm
Torque – Peak	
Max Power	
Gross	538 lb-ft (730 N·m) @ 1600 rpm
Net	510 lb-ft (692 N·m) @ 1600 rpm
Standard Power	
Gross	530 lb-ft (719 N·m) @ 1300 rpm
Net	508 lb-ft (689 N·m) @ 1000 rpm
Economy Power	
Gross	527 lb-ft (715 N·m) @ 1200 rpm
Net	508 lb-ft (689 N·m) @ 1200 rpm
Torque rise	33%

NOTE: Gross horsepower and torque per SAE J1995.
Net horsepower and torque per SAE J1349.

DRIVETRAIN

Transmission	4F/3R Proportional w/Electronic Control Module torque sensing autoshift/manual shift and modulation	
Gears	Helical cut	
Gear ratios	Forward	Reverse
1st	4.012	3.804
2nd	2.174	2.061
3rd	1.088	1.031
4th	0.619	NA
Torque converter		
Stall ratio	2.66:1	
Differential	Limited slip w/45% transfer on front and rear axles	
Front and rear axle		
Differential ratio	3.18	
Planetary ratio	6.40	
Final axle ratio	20.36	
Planetaries	Outboard	
Service brakes	Hydraulically actuated, maintenance-free, multiple wet disc w/accumulator to all four wheels	
Brake surface area	355 in ² per hub (0.229 m ²)	
Parking brakes	Spring-applied hydraulic release disc on transmission output shaft	
Travel speeds – mph (km/h) w/20.5 x 25 L3 tires	Forward	Reverse
1st	4.3 (6.9)	4.5 (7.3)
2nd	8.4 (13.5)	8.8 (14.2)
3rd	14.9 (23.9)	15.6 (25.0)
4th	24.0 (38.6)	NA

NOTE: Travel speeds at full engine throttle.

ELECTRICAL

Voltage	24 Volts, negative ground
Alternator	65 amp
Batteries	(2) 12 Volt

HYDRAULICS

Pump (steering/implement)	Closed centered pressure/flow compensated
Variable displacement	5.49 in ³ /rev 45.2 gpm @ 2000 rpm @ 3600 psi (171 L/min @ 2000 rpm @ 24 822 kPa)
Loader control valve	Closed-center, sectional 2, 3 or 4-spool with pilot control for lift, tilt and auxiliary hydraulics, electromagnetic detents in float, raise and rollback
Loader auxiliary steering	Hydraulic orbital center-pivot articulating w/on-demand oil flow
High pressure standby	3625 psi (25 000 kPa)
Filtration	10-micron, full flow replaceable cartridges on return line, condition indicator light for filter

CYLINDERS

Lift cylinder	
Bore diameter	4.75 in (120.6 mm)
Rod diameter	2.50 in (63.5 mm)
Stroke	31.00 in (787.6 mm)
Dump cylinder (Z-Bar & XR)	
Bore diameter	5.00 in (127.0 mm)
Rod diameter	3.00 in (76.2 mm)
Stroke	24.40 in (619.7 mm)
Dump cylinders (XT)	
Bore diameter	4.50 in (114.3 mm)
Rod diameter	2.50 in (63.5 mm)
Stroke	32.58 in (819.9 mm)

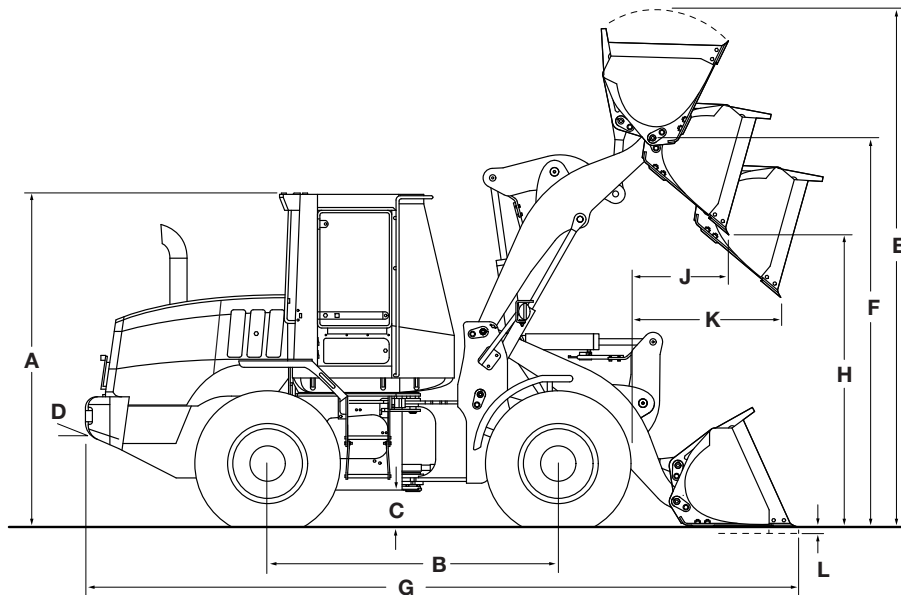

DIMENSIONS

Height to –		
A.	Top of ROPS cab	133.6 in (3393 mm)
	Drawbar	39.0 in (992 mm)
B.	Wheelbase	114.2 in (2900 mm)
C.	Ground clearance	14.4 in (365 mm)
D.	Angle of departure	32°
Width –		
	Overall* w/o bucket	99.3 in (2523 mm)
	Centerline tread	76.8 in (1950 mm)
	Turning radius* – outside	206.7 in (5250 mm)
Turning angle –		
	From center	40°
	Total angle	80°
	Rear axle oscillation, total	24°

NOTE: *Dimensions taken with 20.5x25 L2/L3/XTLA TL tires. Additional dimensions on pages 3 & 4.

WEIGHT ADJUSTMENTS

Select Options	Weight Adjustment	Tipping Load Adjustment Straight	Tipping Load Adjustment 40° Turn
20.5x25 12 ply L2 tires	-100 lb (-45 kg)	-76 lb (-35 kg)	-67 lb (-30 kg)
20.5x25 12 ply L3 tires	+228 lb (+104 kg)	+173 lb (+78 kg)	+153 lb (+69 kg)
20.5R25 XHA TL tires	+380 lb (+172 kg)	+288 lb (+131 kg)	+255 lb (+116 kg)
Standard counterweight	-854 lb (-387 kg)	-2,044 lb (-927 kg)	-1,713 lb (-777 kg)
Open ROPS	-295 lb (-134 kg)	-299 lb (-136 kg)	-276 lb (-125 kg)

NOTE: **Unit equipped with Z-Bar loader arms, 2.5 yd³ (1.96 m³) general purpose pin on bucket w/bolt-on edge, 20.5R25 XTLA Michelin tires, ROPS cab with heater and A/C, full counterweight, standard batteries, front and rear fenders, full fuel and 175 lb (79 kg) operator. Adjust select options from rated weight.

PERFORMANCE DATA

621E Z-Bar*	3.0 yd ³ GP (2.29 m ³)	2.75 yd ³ GP (2.10 m ³)	2.75 yd ³ GP (2.10 m ³)
	Bucket w/Bolt-on Edge	Bucket w/Bolt-on Edge	Bucket w/Teeth & Segments
SAE bucket capacity – struck	2.56 yd ³ (1.96 m ³)	2.32 yd ³ (1.77 m ³)	2.32 yd ³ (1.77 m ³)
Heaped	3.00 yd ³ (2.29 m ³)	2.75 yd ³ (2.10 m ³)	2.75 yd ³ (2.10 m ³)
Bucket width – outside	102.4 in (2602 mm)	102.4 in (2602 mm)	102.4 in (2602 mm)
Bucket weight	1,951 lb (885 kg)	1,856 lb (842 kg)	1,923 lb (872 kg)
E. Operating height – fully raised w/spillguard	198.1 in (5032 mm)	195.1 in (4955 mm)	195.1 in (4955 mm)
F. Hinge pin height – fully raised	150.8 in (3830 mm)	150.8 in (3830 mm)	150.8 in (3830 mm)
G. Overall length – bucket level on ground	290.7 in (7384 mm)	288.0 in (7316 mm)	293.8 in (7463 mm)
Dump angle – fully raised	55°	55°	55°
H. Dump height – fully raised, 45° dump	110.3 in (2801 mm)	112.0 in (2845 mm)	108.2 in (2749 mm)
J. Bucket reach – fully raised, 45° dump	39.9 in (1013 mm)	38.1 in (969 mm)	42.2 in (1071 mm)
K. Bucket reach – 7 ft 0 in (2.13 m) height, 45° dump	59.6 in (1515 mm)	58.8 in (1493 mm)	60.8 in (1544 mm)
Operating load – ISO	9,918 lb (4499 kg)	10,063 lb (4564 kg)	10,019 lb (4544 kg)
Maximum material density – ISO	3,306 lb/yd ³ (1962 kg/m ³)	3,659 lb/yd ³ (2171 kg/m ³)	3,643 lb/yd ³ (2162 kg/m ³)
Tipping load – ISO			
Straight	22,795 lb (10 339 kg)	23,098 lb (10 477 kg)	23,009 lb (10 437 kg)
40° turn	19,836 lb (8998 kg)	20,126 lb (9129 kg)	20,037 lb (9089 kg)
Lift capacity –			
Full height	16,363 lb (7422 kg)	16,464 lb (7468 kg)	16,396 lb (7437 kg)
Maximum reach	23,114 lb (10 484 kg)	23,221 lb (10 533 kg)	23,153 lb (10,502 kg)
Ground	22,841 lb (10 360 kg)	24,369 lb (11 054 kg)	24,323 lb (11 033 kg)
Breakout force w/tilt cylinder	23,249 lb (10 546 kg)	24,827 lb (11 261 kg)	24,762 lb (11 232 kg)
Maximum rollback –			
Ground	41°	40°	41°
Carry position	44°	44°	44°
@ Maximum reach	53°	53°	53°
@ Full height	55°	55°	55°
L. Dig depth	3.4 in (87 mm)	3.2 in (81 mm)	3.5 in (89 mm)
Maximum grading angle w/bucket – back dragging	61°	60°	62°
Loader clearance circle	454.7 in (11 549 mm)	453.1 in (11 507 mm)	456.5 in (11 595 mm)

621E XT	3.0 yd ³ GP (2.4 m ³)	2.5 yd ³ GP (1.96 m ³)
	ACS Bucket w/Edge**	ACS Bucket w/Edge**
E. Operating height – fully raised w/spillguard	215.8 in (5482 mm)	210.5 in (5347 mm)
F. Hinge pin height – fully raised	155.8 in (3956 mm)	155.8 in (3956 mm)
G. Overall length – bucket level on ground	298.9 in (7593 mm)	294.0 in (7468 mm)
Dump angle – fully raised	55°	55°
H. Dump height – fully raised, 45° dump	109.9 in (2792 mm)	113.1 in (2872 mm)
J. Bucket reach – fully raised, 45° dump	48.7 in (1141 mm)	44.9 in (1141 mm)
K. Bucket reach – 7 ft 0 in (2.13 m) height, 45° dump	66.7 in (1694 mm)	66.6 in (1692 mm)
Operating load – ISO	8,435 lb (3826 kg)	8,512 lb (3861 kg)
Maximum material density – ISO	2,669 lb/yd ³ (1584 kg/m ³)	3,200 lb/yd ³ (1899 kg/m ³)
Tipping load – ISO		
Straight	19,489 lb (8840 kg)	19,690 lb (8931kg)
40° turn	16,869lb (7652 kg)	17,024 lb (7722 kg)
Lift capacity –		
Full height	14,316 lb (6494 kg)	14,246 lb (6462 kg)
Maximum reach	20,401 lb (9254 kg)	20,275 lb (9197 kg)
Ground	36,131 lb (16 389 kg)	35,388 lb (16 052 kg)
Breakout force – dump cylinder	24,298 lb (11 021 kg)	26,756 lb (12 137 kg)
Loader clearance circle	452.3 in (11 489 mm)	450.3 in (11 438 mm)

621E XR	3.0 yd ³ GP (2.29 m ³)	2.75 yd ³ GP (2.10 m ³)	2.75 yd ³ GP (2.10 m ³)
	Bucket w/Bolt-on Edge	Bucket w/Bolt-on Edge	Bucket w/Teeth & Segments
E. Operating height – fully raised w/spillguard	214.4 in (5445 mm)	211.3 in (5368 mm)	211.3 in (5368 mm)
F. Hinge pin height – fully raised	167.0 in (4243 mm)	167.1 in (4243 mm)	167.1 in (4243 mm)
G. Overall length – bucket level on ground	306.8 in (7792 mm)	304.1 in (7725 mm)	309.9 in (7871 mm)
Dump angle – fully raised	50°	50°	50°
H. Dump height – fully raised, 45° dump	126.5 in (3214 mm)	128.3 in (3259 mm)	124.5 in (3162 mm)
J. Bucket reach – fully raised, 45° dump	40.5 in (1029 mm)	38.7 in (984 mm)	42.8 in (1086 mm)
K. Bucket reach – 7 ft 0 in (2.13 m) height, 45° dump	73.7 in (1873 mm)	72.8 in (1850 mm)	75.1 in (1908 mm)
Operating load – ISO	8,089 lb (3669 kg)	8,210 lb (3724 kg)	8,167 lb (3705 kg)
Maximum material density – ISO	2,696 lb/yd ³ (1600 kg/m ³)	2,986 lb/yd ³ (1772 kg/m ³)	2,970 lb/yd ³ (1762 kg/m ³)
Tipping load – ISO			
Straight	18,680 lb (8473 kg)	18,931 lb (8587 kg)	18,845 lb (8548 kg)
40° turn	16,178 lb (7338 kg)	16,420 lb (7448 kg)	16,335 lb (7409 kg)
Lift capacity –			
Full height	15,884 lb (7205 kg)	15,981 lb (7249 kg)	15,914 lb (7218 kg)
Maximum reach	20,521 lb (9308 kg)	20,641 lb (9363 kg)	20,571 lb (9331 kg)
Ground	25,153 lb (11 409 kg)	25,433 lb (11 536 kg)	25,361 lb (11 504 kg)
Breakout force w/tilt cylinder	23,925 lb (10 852 kg)	25,557 lb (11 593 kg)	25,470 lb (11 553 kg)
Loader clearance circle	469.7 in (11 931 mm)	468.0 in (11 887 mm)	471.8 in (11 983 mm)

PERFORMANCE DATA

621E Z-Bar*	2.5 yd ³ GP (1.96 m ³)	2.5 yd ³ GP (1.96 m ³)
	Bucket w/Bolt-on Edge	Bucket w/Teeth & Segments
SAE bucket capacity – struck	2.17 yd ³ (1.66 m ³)	2.17 yd ³ (1.66 m ³)
Heaped	2.56 yd ³ (1.96 m ³)	2.56 yd ³ (1.96 m ³)
Bucket width – outside	102.4 in (2602 mm)	102.4 in (2602 mm)
Bucket weight	1,792 lb (813 kg)	1,859 lb (843 kg)
E. Operating height – fully raised w/spillguard	194.0 in (4927 mm)	194.0 in (4927 mm)
F. Hinge pin height – fully raised	150.8 in (3830 mm)	150.8 in (3830 mm)
G. Overall length – bucket level on ground	285.1 in (7241 mm)	290.8 in (7387 mm)
Dump angle – fully raised	55°	55°
H. Dump height – fully raised, 45° dump	114.0 in (2895 mm)	110.2 in (2799 mm)
J. Bucket reach – fully raised, 45° dump	36.2 in (919 mm)	40.2 in (1021 mm)
K. Bucket reach – 7 ft 0 in (2.13 m) height, 45° dump	57.8 in (1467 mm)	59.9 in (1521 mm)
Operating load – ISO	10,190 lb (4622 kg)	10,146 lb (4602 kg)
Maximum material density – ISO	3,980 lb/yd ³ (2362 kg/m ³)	3,963 lb/yd ³ (2352 kg/m ³)
Tipping load – ISO		
Straight	23,376 lb (10 603 kg)	23,289 lb (10 564 kg)
40° turn	20,379 lb (9244 kg)	20,292 lb (9204 kg)
Lift capacity –		
Full height	16,533 lb (7499 kg)	16,465 lb (7469 kg)
Maximum reach	23,296 lb (10 567 kg)	23,228 lb (10 536 kg)
Ground	25,806 lb (11 705 kg)	25,768 lb (11 688 kg)
Breakout force w/tilt cylinder	26,577 lb (12 055 kg)	26,513 lb (12 026 kg)
Maximum rollback –		
Ground	40°	40°
Carry position	44°	44°
@ Maximum reach	53°	53°
@ Full height	55°	55°
L. Dig depth	3.0 in (75 mm)	3.3 in (83 mm)
Maximum grading angle w/bucket – back dragging	60°	61°
Loader clearance circle	451.4 in (11 466 mm)	454.7 in (11 551 mm)

621E XT	2.5 yd ³ GP (1.96 m ³)	2.5 yd ³ GP (1.96 m ³)
	Case Bucket w/Edge***	Case Bucket w/Teeth
E. Operating height – fully raised w/spillguard	210.7 in (5353 mm)	210.7 in (5352 mm)
F. Hinge pin height – fully raised	155.8 in (3957 mm)	155.8 in (3957 mm)
G. Overall length – bucket level on ground	300.8 in (7640 mm)	306.7 in (7791 mm)
Dump angle – fully raised	55°	55°
H. Dump height – fully raised, 45° dump	108.7 in (2761 mm)	104.9 in (2663 mm)
J. Bucket reach – fully raised, 45° dump	50.2 in (1275 mm)	54.1 in (1375 mm)
K. Bucket reach – 7 ft 0 in (2.13 m) height, 45° dump	69.5 in (1766 mm)	71.2 in (1809 mm)
Operating load – ISO	8,267 lb (3750 kg)	8,206 lb (3722 kg)
Maximum material density – ISO	3,327 lb/yd ³ (1974 kg/m ³)	3,302 lb/yd ³ (1959 kg/m ³)
Tipping load – ISO		
Straight	19,068 lb (8649 kg)	18,945 lb (8593 kg)
40° turn	16,534 lb (7500 kg)	16,411 lb (7444 kg)
Lift capacity –		
Full height	14,899 lb (6758 kg)	14,786 lb (6707 kg)
Maximum reach	20,650 lb (9367 kg)	20,545 lb (9319 kg)
Ground	33,099 lb (15 013 kg)	32,921 lb (14 933 kg)
Breakout force – dump cylinder	23,531 lb (10 674 kg)	21,376 lb (9696 kg)
Loader clearance circle	453.1 in (11 508 mm)	455.7 in (11 574 mm)

621E XR	2.5 yd ³ GP (1.96 m ³)	2.5 yd ³ GP (1.96 m ³)
	Bucket w/Bolt-on Edge	Bucket w/Teeth & Segments
E. Operating height – fully raised w/spillguard	210.3 in (5340 mm)	210.3 in (5340 mm)
F. Hinge pin height – fully raised	167.1 in (4243 mm)	167.1 in (4243 mm)
G. Overall length – bucket level on ground	301.2 in (7651 mm)	306.9 in (7796 mm)
Dump angle – fully raised	50°	50°
H. Dump height – fully raised, 45° dump	130.3 in (3308 mm)	126.5 in (3212 mm)
J. Bucket reach – fully raised, 45° dump	36.8 in (934 mm)	40.8 in (1036 mm)
K. Bucket reach – 7 ft 0 in (2.13 m) height, 45° dump	71.6 in (1819 mm)	74.0 in (1880 mm)
Operating load – ISO	8,309 lb (3769 kg)	8,266 lb (3794 kg)
Maximum material density – ISO	3,246 lb/yd ³ (1926 kg/m ³)	3,229 lb/yd ³ (1916 kg/m ³)
Tipping load – ISO		
Straight	19,145 lb (8684 kg)	19,060 lb (8646 kg)
40° turn	16,617 lb (7537 kg)	16,532 lb (7499 kg)
Lift capacity –		
Full height	16,047 lb (7279 kg)	15,980 lb (7248 kg)
Maximum reach	20,729 lb (9402 kg)	20,659 lb (9371 kg)
Ground	25,667 lb (11 642 kg)	25,593 lb (11 609 kg)
Breakout force w/tilt cylinder	27,375 lb (12 417 kg)	27,287 lb (12 377 kg)
Loader clearance circle	466.0 in (11 836 mm)	469.8 in (11 932 mm)

NOTE: *Z-Bar performance data shown w/full counterweight
 **XT lift arm with buckets for ACS Pro Series 2000® size 30 HD coupler.
 ***XT lift arm with bucket for Case coupler

Performance data unit equipped with 20.5R25 XTLA tires, ROPS cab w/heater and A/C, full counterweight, standard batteries, front and rear fenders, full fuel and 175 lb (79 kg) operator. Specifications per SAE J732, J1234, J695, J742 and J818.

INSTRUMENTATION

Electronic Information Center
Displays/Gauges –
Speedometer
Tachometer
Direction selected F/N/R
Transmission modes – Auto shift/Manual shift
Gear position
Engine coolant temperature
Fuel level
Transmission oil temperature
Hydraulic oil temperature
Hourmeter
Work mode
Indicator lights –
Low fuel
Turn signals
High beam lights
Grid heater*
Brake pressure
Master indicator
Secondary steering*
Parking brake
Audible alarms –
Caution alarm
Critical alarm
Backup alarm
Horn

NOTE: *If equipped with option.

OPERATOR ENVIRONMENT

ROPS cab w/ heat
Key start
Articulated power steering w/tilt column
Fully adjustable, suspension seat
Foot throttle
1-Lever loader control w/wrist rest
Cup holder
Coat hook
(1) Interior rearview mirror
2 in (51 mm) retractable seat belt
Storage tray behind seat
Cooled lunch box
Single brake pedal
F/N/R shuttle switch
External rear view mirrors
Lock box
Pressurized air filtering
Anti-glare window strip
Defroster
Side window, partial/fully open
Dome light
Wipers, rear and intermittent front
Windshield washers, front and rear
Rubber floor mat

LOADER

Z-bar loader linkage
Single control for lift and tilt
Positive hold float
Automatic return-to-dig
Automatic height control
Automatic return-to-travel
Brake pedal transmission disconnect
Bucket position indicator on bucket

CYCLE TIME

Raise w/rated bucket load	6.3 sec
Dump w/rated bucket load	
Z-Bar	1.3 sec
XT	1.7 sec
Lower (empty)	
Power down	4.7 sec
Float down	4.6 sec

SERVICE CAPACITIES

Fuel tank	65 gal (246 L)
Hydraulic system	
Total	39 gal (147.6 L)
Reservoir	24 gal (90.8 L)
Transmission	
Service w/filter	5.0 gal (18.9 L)
Front and rear axle	
Front axle	23.2 qt (22.0 L)
Rear axle	23.2 qt (22.0 L)
Engine oil w/filter	13.9 qt (13.2 L)
Cooling system (-40)	38 qt (36.0 L)

OPERATING WEIGHTS

Z-Bar

Unit equipped with ROPS cab with heater and A/C, full counterweight, 20.5R25 XTLA Michelin tires, front and rear fenders, 2.5 yd³ (1.96 m³) general purpose loader bucket w/edge, full fuel, 175 lb (79 kg)
operator 27,406 lb (12 431 kg)

XT

Unit equipped with ROPS cab with heater and A/C, full counterweight, 20.5R25 XTLA Michelin tires, 2.5 yd³ (1.96 m³) ACS loader bucket, standard batteries, full fuel, 175 lb (79 kg)
operator 28,709 lb (13 022 kg)

XR

Unit equipped with ROPS cab with heater and A/C, full counterweight, 20.5R25 XTLA Michelin tires, front and rear fenders, 2.5 yd³ (1.96 m³) general purpose loader bucket w/edge, full fuel, 175 lb (79 kg)
operator 27,604 lb (12 521 kg)

STANDARD EQUIPMENT

OPERATOR'S ENVIRONMENT

See page 5

ENGINE

Case Family IV 667TA/EDB
Tier III certified
Selectable work modes
 Max power
 Auto power
 Standard power
 Economy power
Turbocharger
Charge air cooling
Automatic fan belt tensioner
Integral engine oil cooling
Fuel filter w/water trap
Dual element air cleaner
65 amp alternator
(2) 700 CCA 12-volt batteries
Liquid-cooled radiator
Non spark-arresting muffler
Mid-mounted cooling module
Common rail electronic fuel injection

OPTIONAL EQUIPMENT

OPERATOR'S COMPARTMENT

Cloth-covered air-suspension seat
Sound Shield noise suppression package
Cab air-conditioning w/heater
Radio
Radio-ready (12 or 24-volt)
Auxiliary power (12-volt)
Cab convenience package
RH steps and platform
Rotating beacon
Second brake pedal
Open ROPS
Joystick steering

LOADER

See page 5

DRIVETRAIN

4-wheel drive
4F/3R Selectable autoshift/manual shift transmission
Electronic Control Module – Programmable, computer controlled proportional shifting with programmable gear selection
Onboard diagnostics
Single lever electronic shift control
F/N/R switch in loader control handle
Downshift button
Torque converter
Outboard planetary axles
Limited-slip differentials
Transmission oil cooler
Brake pedal transmission disconnect
Hydraulic wet disc brakes
Spring-applied hydraulic release parking brake
Limp-Home Mode
Lubed-for-life drive shaft

ENGINE

Cold weather package
 Heavy-duty batteries
 Fuel heater
 Hydraulic oil cooler bypass
 Low temperature hydraulic oil
 Grid heater

LOADER

Hydraulic attachment coupler systems
Attachment auxiliary hydraulics
Buckets (see page 3 & 4)
XT Linkage
XR Extended reach

HYDRAULICS

Auxiliary hydraulics
Ride Control
Secondary steering
3 or 4-spool loader valves with 2 or 3-lever loader control
Hydraulic reversing fan
Hydraulic cooler

HYDRAULICS

Single lever 2-spool loader control valve
Low-effort steering
Hydraulic driven fan
(8) Diagnostic quick couplers

OTHER

Electric hood lift
Front and rear fenders
Lights –
 (2) Front driving headlights (high/low beam)
 (2) Front flood
 (2) LED stop and tail lights
 (2) Rear flood
 Front and rear turn signal/flash
Standard counterweight
Drawbar hitch
Articulation locking bar
Lift arm locking bar
Lift and tie-down points – front/rear
Backup alarm
Remote drain points

TIRES

20.5-25 12 PR L3 bias (rock)
20.5 R25 radial (dirt/traction)
20.5 R25 radial (rock)

OTHER

Special paint
Full coverage fenders
Belly pan
Tool box
Full counterweight - Z-Bar
Temperature controlled fan

NOTE: All specifications are stated in accordance with SAE Standards or Recommended Practices, where applicable.

NOTE: All engines meet current EPA emissions requirements.

IMPORTANT: Case Construction Equipment Inc. reserves the right to change these specifications without notice and without incurring any obligation relating to such change. Case Construction Equipment Inc. does not warrant the safety or reliability of attachments from other manufacturers.

Case is a registered trademark of CNH America LLC. Any trademarks referred to herein, in association with goods and/or services of companies other than CNH America LLC, are the property of those respective companies.