

ENGINE

Model	Isuzu AU-4LE2X
Type	4-stroke
Cylinders	4
Bore/Stroke	3.35 in x 3.78 in (85 x 96 mm)
Displacement	133 in ³ (2179 cc)
Fuel injection	Direct
Fuel injection pump	Mechanical
Fuel	Diesel
Fuel filter	In-line strainer
Cooling	Liquid
Horsepower per SAE J1349	
Net	54 hp (40 kW) @ 2000 rpm
Maximum torque @ 1500 rpm	
Net	155 lb-ft (210 N-m)

BOOM/ARM

Swing Boom	
Length	11 ft 7 in (3.50 m)
Boom w/arm cylinder & plumbing	1,084 lb (492 kg)
Hoist cylinders (1)	227 lb (103 kg) ea
Total weight	1,311 lb (595 kg)
5 ft 7 in Arm (1.71 m)	
Bare arm	308 lb (140 kg)
Bucket cylinder linkage & plumbing	254 lb (115 kg)
Total weight	562 lb (255 kg)
6 ft 11 in Arm (2.12 m)	
Bare arm	408 lb (185 kg)
Bucket cylinder linkage & plumbing	254 lb (115 kg)
Total weight	662 lb (300 kg)
Boom swing left	80°
Boom swing right	50°

UNDERCARRIAGE

Number of rollers	
Top, each track	1
Bottom, each track	5
Number of shoes	
Triple grouser – each side	39
Link pitch	6.06 in (154 mm)

HYDRAULICS

Pumps (2)	Variable displacement axial piston design
Capacity –	
Maximum	2 x 18.0 gpm (68 L/min)
System relief pressure –	
Standard	4,264 psi (29.4 MPa)
Control valves –	
2-blade, boom swing	
4-spool section for right track travel, boom, bucket and arm	
5-spool section for left track travel, boom, auxiliary, swing and arm	
Boom anti-drift valves	
Pilot control hydraulic system –	
Pump (1)	Gear design
Maximum capacity	5.7 gpm (21.4 L/min)
Relief pressure	609 psi (4.2 MPa)
Swing –	
Motor (1)	Fixed displacement axial piston design
Speed	0-9.5 rpm
Brake	Mechanical disk
Tail swing radius	4 ft 0 in (1.21 m)
Travel –	
Motor (2)	Two-speed axial piston design
Final drive	Planetary gear reduction
Drawbar pull	13,309 lb (59.2 kN)
Travel Speeds –	
Auto shift high to low	
	Forward/Reverse
Low	2.1 mph (3.4 km/h)
High	3.2 mph (5.1 km/h)
Travel control valve –	
Dual stage relief and counter-balance design	

HYDRAULIC CYLINDERS

Boom cylinders (1) –	
Bore diameter	4.3 in (110 mm)
Rod diameter	2.8 in (70 mm)
Stroke	35.9 in (911 mm)
Arm cylinder (1) –	
Bore diameter	3.7 in (95 mm)
Rod diameter	2.4 in (60 mm)
Stroke	31.4 in (797 mm)
Bucket cylinder (1) –	
Bore diameter	3.3 in (85 mm)
Rod diameter	2.2 in (55 mm)
Stroke	26.2 in (665 mm)
Boom Swing Cylinder	
Bore diameter	3.7 in (95 mm)
Rod diameter	2.2 in (55 mm)
Stroke	25.2 in (640 mm)

ELECTRICAL

Voltage	24 volts, negative ground
Alternator	50 amp
Batteries (1)	Low-maintenance 64 Ah (5 hr rate)

SERVICE CAPACITIES

Hydraulic tank	
Refill capacity	13 gal (50 L)
Total system	26 gal (97.3 L)
Final drive (per side)	1.2 qt (1.1 L)
Engine	
w/filter change	9.5 qt (9.0 L)
Fuel	26 gal (100 L)
Radiator	10.8 qt (10.2 L)

OPERATING WEIGHT

With 5 ft 7 in (1.71 m) arm, 17.7 in (450 mm) track shoes, 460 lb (210 kg) bucket, 165 lb (75 kg) operator, full fuel and standard equipment 18,585 lb (8430 kg)

LIFT CAPACITIES

5 ft 7 in (1.71 m) Arm Lift capacities calculated using a 460 lb (209 kg) bucket, counterweight operating in "Standard" Mode, blade down.

Load (Lift Point) Height	5 ft (1.52 m)		10 ft (3.05 m)		15 ft (5.57 m)		20 ft (6.10 m)		MAXIMUM REACH		
	END	SIDE	END	SIDE	END	SIDE	END	SIDE	@	END	SIDE
+15 ft (4.57 m)					2,902 lb* (1316 kg*)	2,902 lb* (1316 kg*)			19 ft 3 in (5.86 m)	3,002 lb* (1362 kg*)	2,502 lb (1135 kg)
+10 ft (3.05 m)					3,552 lb* (1611 kg*)	3,552 lb* (1611 kg*)			21 ft 8 in (6.60 m)	3,152 lb* (1430 kg*)	2,002 lb (908 kg)
+5 ft (1.52 m)			8,952 lb* (4060 kg*)	6,452 lb (2926 kg)	5,052 lb* (2291 kg*)	3,502 lb (1588 kg)	4,052 lb* (1838 kg*)	2,202 lb (999 kg)	22 ft 4 in (6.80 m)	3,402 lb* (1543 kg*)	1,852 lb (840 kg)
Ground-line			9,152 lb* (4151 kg*)	6,002 lb (2722 kg)	6,452 lb* (2926 kg*)	3,302 lb (1498 kg)	4,502 lb* (2042 kg*)	2,102 lb (953 kg)	21 ft 5 in (6.52 m)	4,052 lb* (1838 kg*)	1,902 lb (863 kg)
-5 ft (-1.52 m)			12,102 lb* (5489 kg*)	6,052 lb (2745 kg)	6,802 lb* (3085 kg*)	3,202 lb (1452 kg)			18 ft 6 in (5.63 m)	4,702 lb* (2133 kg*)	2,402 lb (1089 kg)
-10 ft (-3.05 m)			9,902 lb* (4491 kg*)	6,202 lb (2813 kg)							

6 ft 11 in (2.12 m) Arm Lift capacities calculated using a 420 lb (191 kg) bucket, counterweight operating in "Standard" Mode, blade down.

Load (Lift Point) Height	5 ft (1.52 m)		10 ft (3.05 m)		15 ft (5.57 m)		20 ft (6.10 m)		MAXIMUM REACH		
	END	SIDE	END	SIDE	END	SIDE	END	SIDE	@	END	SIDE
+15 ft (4.57 m)									20 ft 9 in (6.32 m)	2,703 lb* (1266 kg*)	2,253 lb* (1022 kg*)
+10 ft (3.05 m)					2,903 lb* (1,317 kg*)	2,903 lb* (1,317 kg*)	3,203 lb* (1453 kg*)	2,302 lb (1044 kg)	22 ft 11 in (6.98 m)	2,803 lb* (1271 kg*)	1,802 lb (817 kg)
+5 ft (1.52 m)			7,303 lb* (3312 kg*)	6,602 lb (2995 kg)	4,503 lb* (2042 kg*)	3,502 lb (1589 kg)	3,703 lb* (1679 kg*)	2,202 lb (999 kg)	23 ft 7 in (7.18 m)	3,053 lb* (1385 kg*)	1,652 lb (749 kg)
Ground-line			9,803 lb* (4446 kg*)	6002 lb (2723 kg)	6,103 lb* (2768 kg*)	3,252 lb (1475 kg)	4,353 lb* (1974 kg*)	2,102 lb (954 kg)	22 ft 8 in (6.90 m)	3,553 lb* (1611 kg*)	1,752 lb (795 kg)
-5 ft (-1.52 m)			12,203 lb* (5535 kg*)	5,902 lb (2677 kg)	6,753 lb* (3063 kg*)	3,152 lb (1430 kg)	4,503 lb* (2042 kg*)	2,052 lb (931 kg)	20 ft 1 in (6.12 m)	4,353 lb* (1974 kg*)	2,102 lb (954 kg)
-10 ft (-3.05 m)			10,803 lb* (4900 kg*)	6,052 lb (2745 kg)	6,053 lb* (2745 kg*)	3,252 lb (1475 kg)					

*Lift capacities do not exceed 75% of the minimum tipping load or 87% of the hydraulic lift capacity. Capacities that are marked with an asterisk are hydraulic limited.

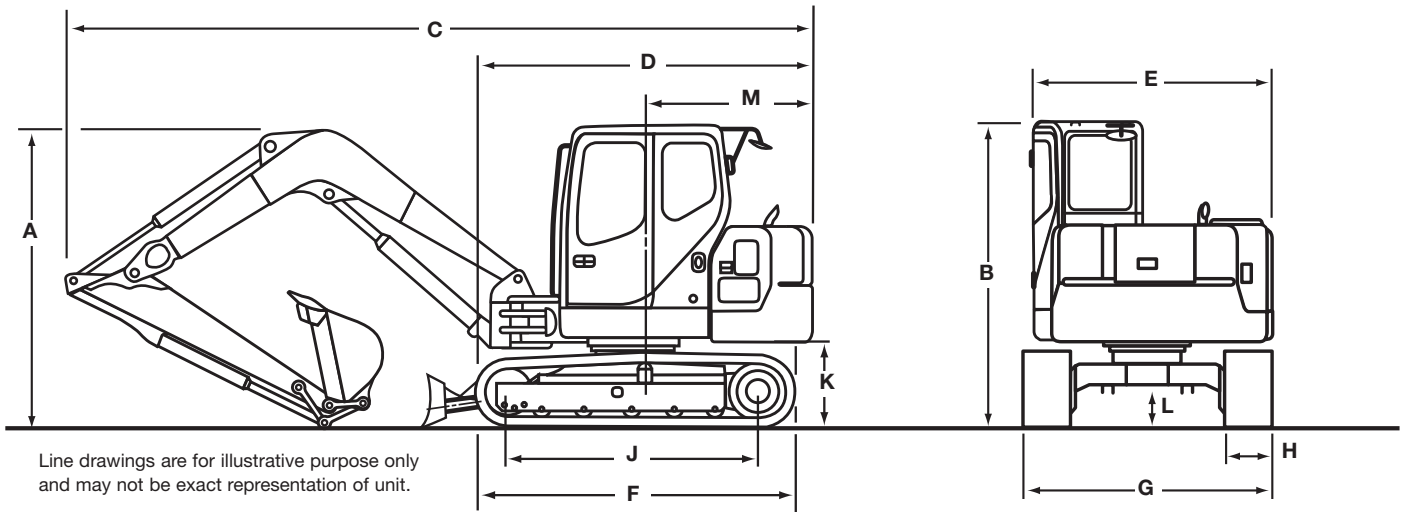

DIMENSIONS

	5 ft 7 in (1.71 m) Arm	6 ft 11 in (2.12 m) Arm
A. Overall height	8 ft 10 in (2.70 m)	9 ft 8 in (2.95 m)
B. Cab height	8 ft 10 in (2.70 m)	8 ft 10 in (2.70 m)
C. Overall length	21 ft 10 in (6.66 m)	22 ft 1 in (6.72 m)
D. w/o attachment	11 ft 6 in (3.51 m)	11 ft 6 in (3.51 m)
E. Width of upperstructure	7 ft 4 in (2.23 m)	7 ft 4 in (2.23 m)
F. Track overall length	9 ft 4 in (2.85 m)	9 ft 4 in (2.85 m)
G. Track overall width w/17.7 in (450 mm) shoes	7 ft 7 in (2.32 m)	7 ft 7 in (2.32 m)
H. Track shoe width	17.7 in (450 mm)	17.7 in (450 mm)
J. Center to center (idler to sprocket)	7 ft 3 in (2.21 m)	7 ft 3 in (2.21 m)
K. Upperstructure ground clearance	2 ft 5 in (0.75 m)	2 ft 5 in (0.75 m)
L. Minimum ground clearance	1 ft 2 in (0.36 m)	1 ft 2 in (0.36 m)
M. Tail swing radius	5 ft 5 in (1.66 m)	5 ft 5 in (1.66 m)
Dozer blade width	7 ft 7 in (2.32 m)	7 ft 7 in (2.32 m)
Dozer blade height	1 ft 6 in (0.45 m)	1 ft 6 in (0.45 m)
Working weight*	18,585 lb (8430 kg)	18,685 lb (8475 kg)
Ground pressure	5.5 psi (38.0 kPa)	5.5 psi (38.0 kPa)

*With 17.7 in (460 mm) track shoe, 460 lb (210 kg) bucket, 165 lb (75 kg) operator, full fuel and standard equipment.

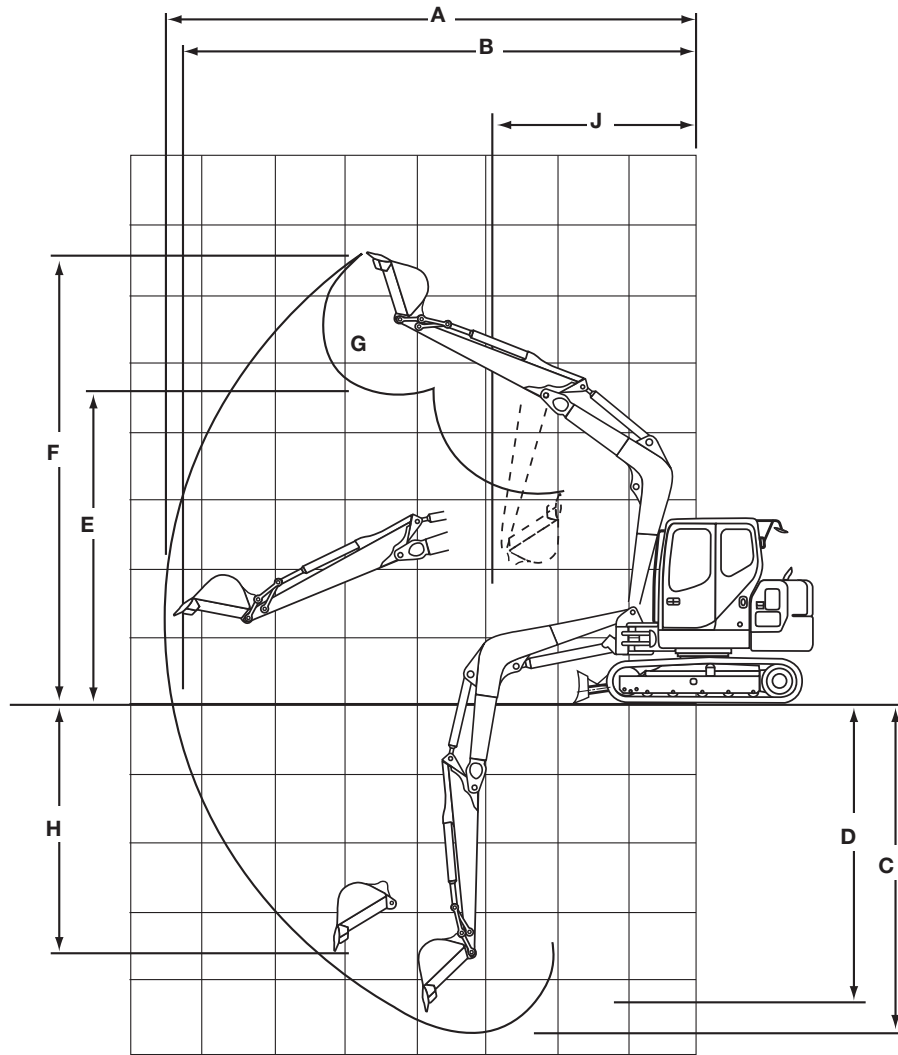

PERFORMANCE SPECS

	5 ft 7 in (1.71 m) Arm	6 ft 11 in (2.12 m) Arm
A. Maximum dig radius	23 ft 1 in (7.03 m)	24 ft 3 in (7.40 m)
B. Dig radius at groundline	22 ft 7 in (6.89 m)	23 ft 10 in (7.27 m)
C. Maximum dig depth	13 ft 9 in (4.18 m)	15 ft 1 in (4.59 m)
D. Dig depth - 8 ft 0 in (2.44 m) level bottom	12 ft 5 in (3.78 m)	13 ft 11 in (4.23 m)
E. Dump height	14 ft 5 in (4.39 m)	15 ft 1 in (4.60 m)
F. Overall reach height	21 ft 0 in (6.39 m)	21 ft 8 in (6.60 m)
G. Bucket rotation	177°	177°
H. Vertical straight wall dig depth	10 ft 1 in (3.08 m)	11 ft 8 in (3.55 m)
J. Minimum swing radius	9 ft 0 in (2.75 m)	9 ft 7 in (2.91 m)
Arm digging force	8,610 lb (38.3 kN)	7,644 lb (34.0 kN)
Bucket digging force	12,792 lb (56.9 kN)	12,792 lb (56.9 kN)
Dozer blade cutting edge		
Max. height	1 ft 4 in (0.42 m)	1 ft 4 in (0.42 m)
Dozer blade cutting edge		
Max. depth	8 in (0.21 m)	8 in (0.21 m)

STANDARD EQUIPMENT

OPERATOR'S COMPARTMENT

Cab with Isomount® system
Adjustable deluxe seat with
3 in (76 mm) seat belt
Safety glass
Air conditioning
AM/FM Radio w/auto tuner
Skylight
Sliding front windows
Windshield wiper w/washer
Rear view mirrors

ENGINE

Isuzu AU-4LE2X diesel
Tier IV Stage 1 compliant
Glow plug
Selectable one touch accelerator/decelerator

ELECTRICAL

Batteries (2) 12-Volt
Horn

HYDRAULICS

ISO pattern pilot controls
Position mode selector: S
Variable flow piston pumps
Neutral pump destroke
Auxiliary hydraulic valve
Boom anti-drift valves
Ultra Clean filtration system

UNDERCARRIAGE

Shoes: 17.7 in (450 mm) 3-bar,
39 per side
Track length: 9 ft 4 in (2.85 m)
Track gauge: 6 ft 2 in (1.87 m)
Dozer blade

TRACK DRIVE

2-speed hydrostatic travel
Disc-type parking brakes

UPPERSTRUCTURE

Swing boom: 11 ft 7 in (3.50 m) one piece
Swing brake

OTHER

Counterweight
Single key vandal lockup

OPTIONAL EQUIPMENT

UPPERSTRUCTURE

Arm: 6 ft 11 in (2.18 m)

UPPERCARRIAGE

Track Slides: 24 in (600 mm)
Rubber Link Track

HYDRAULICS

Auxiliary hydraulics
Single acting, one pump (includes
heavy-duty bucket linkage)
Double acting, single or dual
pump (includes heavy-duty
bucket linkage)
Double acting general purpose for use with
thumb kit
Control pattern selector valve

OTHER

Load holding control devices
Cylinder mounted
Hydraulic Coupler

BUCKETS

Application	Width	SAE Heaped Capacity
General purpose	18 in to 30 in (0.457 to 0.762 m)	0.24 yd ³ to 0.45 yd ³ (0.18 m ³ to 0.34 m ³)
Ditching	42 in to 48 in (1.067 to 1.219 m)	0.60 yd ³ to 0.70 yd ³ (0.46 m ³ to 0.54 m ³)

This page intentionally left blank.

NOTE: All specifications are stated in accordance with SAE Standards or Recommended Practices, where applicable.

NOTE: All engines meet current EPA emissions requirements.

IMPORTANT: Case Construction Inc. reserves the right to change these specifications without notice and without incurring any obligation relating to such change. Case Construction Inc. does not warrant the safety or reliability of attachments from other manufacturers.

Case is a registered trademark of CNH America LLC. Any trademarks referred to herein, in association with goods and/or services of companies other than CNH America LLC, are the property of those respective companies.



www.casece.com