

550H

**LT/WT/LGP
CRAWLER DOZER**

ENGINE

Model	Case 4-390 or 4T-390
Cylinders	4
Bore/Stroke	4.02 in x 4.72 in (102 x 120 mm)
Displacement	239 in ³ (3.9 L)
Fuel injection	Direct
Fuel	#2 Diesel
Fuel filter	Spin-on with in-line strainer
Air intake	Cross-flow
Cooling	Liquid
Engine speeds (rpm)	
High idle - no load	2420±50
Rated - full load	2200
Low idle	800-1050
Horsepower per SAE J1349	
Naturally aspirated –	
Net	67 (50 kW) @ 2200 rpm
Gross	75 (56 kW) @ 2200 rpm
Turbocharged –	
Net	70 (52 kW) @ 2200 rpm
Gross	80 (65 kW) @ 2200 rpm
Peak torque –	
Naturally aspirated @ 1600 rpm –	
Net	181 lb-ft (245 N·m)
Gross	191 lb-ft (259 N·m)
Turbocharged @ 1500 rpm –	
Net	220 lb-ft (298 N·m)
Gross	229 lb-ft (309 N·m)
Engine lubrication –	
Pump	Deep sump plate cooler with pressurized under-piston nozzles
Pump operating angle ratings	
Side-to-side	45°
Fore and aft	45°
Oil filtration	Replaceable, spin-on full-flow cartridge

ENGINE COOLING

Radiator –	
Core size area	408 in ² (0.26 m ²)
Rows of tubes	5
Fan –	
Diameter	17.7 in (450 mm)
Ratio	1.35:1

POWERTRAIN

Torque converter	Single-stage
Diameter	11.5 in (292 mm)
Stall ratio	2.34
Drawbar pull* –	
Naturally aspirated –	
1st	22,080 lb (98.2 kN)
2nd	15,873 lb (70.6 kN)
3rd	12,619 lb (56.1 kN)
4th	9,000 lb (40.0 kN)
Turbocharged –	
1st	23,496 lb (106.5 kN)
2nd	16,900 lb (75.2 kN)
3rd	13,442 lb (59.8 kN)
4th	9,596 lb (42.7 kN)
Transmission	Case constant-mesh modulated transmission
Oil filter	10 micron, spin-on replaceable
Gear ratios (fwd/rev) –	
1st	68.2/62.1
2nd	49.5/45.0
3rd	39.7/36.1
4th	28.8/26.2
Travel speeds* –	
Forward	mph (km/h)
1st	2.5 (4.0)
2nd	3.4 (5.5)
3rd	4.2 (6.8)
4th	5.8 (9.3)
Reverse	mph (km/h)
1st	2.7 (4.3)
2nd	3.7 (5.9)
3rd	4.6 (7.4)
4th	6.4 (10.3)

*Measured using standard track chain. Increase travel speeds by 4% and reduce drawbar pull by 4% with the optional CELT track chain.

Parking brakes	Heavy-duty, spring-applied, hydraulic pressure release
Brakes	Foot-operated, low-effort power
Final drive	Spur and bull gear single reduction

HYDRAULIC SYSTEM

Standard equipment pump	
Pump flow @ 2200 rpm @ 2500 psi (172 kPa)	21.9 gpm (82.9 L/min)

CYLINDERS

Lift cylinder (2)	
Bore diameter	3.0 in (76 mm)
Rod diameter	1.75 in (44.5 mm)
Stroke	22.63 in (575 mm)
Angle cylinder (2)	
Bore diameter	3.0 in (76 mm)
Rod diameter	1.75 in (44.5 mm)
Stroke	14.1 in (358 mm)
Tilt cylinder (1)	
Bore diameter	3.50 in (89 mm)
Rod diameter	1.75 in (44.5 mm)
Stroke	5.40 in (137 mm)

UNDERCARRIAGE

Track adjustment	Hydraulic
Frame	Rigid suspension
Length of track on ground	78 in (1.98 m)
Track link pitch –	
Steel	6.29 in (160 mm)
Rubber	6.46 in (164 mm)
Track shoe height –	
Steel	2.06 in (52 mm)
Rubber	1.97 in (50 mm)
Pin diameter	1.13 in (28.7 mm)
Bushing diameter	2.0 in (51 mm)
Bolt diameter	0.562 in (14.2 mm)
Track shoes per side	37
Track rollers per side	6
Carrier rollers per side	1
Track roller rail dia.	6.1 in (155 mm)

ELECTRICAL SYSTEM

Alternator	65 amp
Battery	12-volt low-maintenance 700 cold-cranking amps @ 0° F (-18 C)

OPERATOR ENVIRONMENT

ROPS canopy
"U" in pattern forward/reverse lever
Adjustable armrests
Foot rests
Retractable seat belt, 2 in (51 mm)
Vinyl suspension seat w/back adjustment
Tool storage area

INSTRUMENTATION

Warning lights:
Air filter
Alternator
Engine oil pressure
Hydraulic filter
Transmission filter
Transmission pressure
Gauges:
Battery voltage
Fuel level
Hourmeter
Tachometer
Transmission oil temperature
Water temperature
Audible warnings:
Engine oil pressure
Transmission pressure

BLADE

Blade pitch	55° forward 60° rearward
Lift speed (per second)	22.5 in (0.57 m)
Cutting edge	Reversible and replaceable
Width	8.0 in (203 mm)
Thickness	0.625 in (16 mm)

RIPPER

Max. penetration	15 in (381 mm)
Width	72.4 in (1839 mm)
Cut width	70.1 in (1780 mm)
Ground clearance (at carry)	12.3 in (312 mm)
Points	Replaceable
Max. number of shanks	5
Tooth spacing –	
with 5 teeth	17 in (432 mm)
with 3 teeth	34 in (864 mm)
Hydraulic cylinder (double-acting)	
Diameter	3.0 in (76 mm)
Stroke	10.5 in (267 mm)
Rod	1.5 in (38 mm)

SERVICE CAPACITIES

Fuel tank	30.5 gal (115.5 L)
Engine oil w/filter	11 qt (10.4 L)
Engine oil w/o filter	10 qt (9.5 L)
Engine cooling system	16.5 qt (15.6 L)
Hydraulic reservoir	10.3 gal (39 L)
Final drive (per side)	6.0 qt (5.7 L)
Track rollers (ea.)	0.19 qt (0.18 L)
Front idlers (ea.)	0.42 qt (0.40 L)
Carrier rollers (ea.)	0.25 qt (0.24 L)

OPERATING WEIGHTS

Unit equipped with ROPS, full fuel tank, 170 lb (77 kg) operator, drawbar, side shield, track guides, backup alarm, horn and lights.

Long Track*	14,317 lb (6494 kg)
Wide Track	14,600 lb (6622 kg)
LGP	14,960 lb (6786 kg)

*Includes 500 lb (226 kg) rear counterweight.

Add-on weights –	
Drawbar	30 lb (14 kg)
Ripper (3 shank)	1,270 lb (576 kg)
Winch	1,111 lb (504 kg)
Front counterweight	950 lb (431 kg)
Rear counterweight	500 lb (226 kg)
ROPS heater	70 lb (32 kg)
CELT chain	124 lb (56 kg)
Rubber track	-574 lb (- 260 kg)

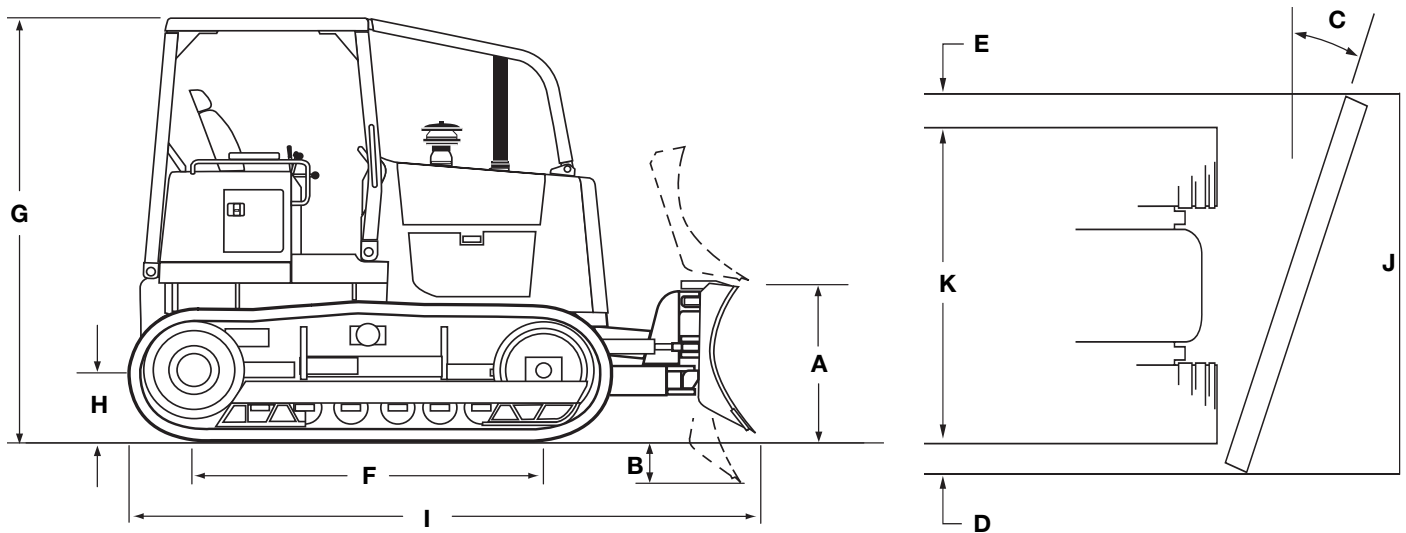

DIMENSIONS

	Long Track (LT)	Wide Track (WT)	Low Ground Pressure (LGP)
BLADES			
Blade width	96 in (2.44 m)	110 in (2.79 m)	110 in (2.79 m)
SAE blade capacity	1.65 yd ³ (1.26 m ³)	1.9 yd ³ (1.45 m ³)	1.9 yd ³ (1.45 m ³)
A. Blade lift above ground	34 in (864 mm)	34 in (864 mm)	34 in (864 mm)
B. Blade depth below ground	19.5 in (495 mm)	19.5 in (495 mm)	19.5 in (495 mm)
C. Blade angle both directions	25°	25°	25°
Blade tilt, each end (up to 8.3°)	14 in (356 mm)	16 in (406 mm)	16 in (406 mm)
Blade height	33 in (838 mm)	33 in (838 mm)	33 in (838 mm)
D. Cast reach	15.2 in (386 mm)	14.1 in (358 mm)	11.1 in (282 mm)
E. Cut reach	2.8 in (71 mm)	1.6 in (41 mm)	-1.3 in (-33 mm)
TRACKS			
Track gauge	53 in (1.35 m)	64 in (1.63 m)	64 in (1.63 m)
Shoe width	16 in (406 mm)	20 in (508 mm)	26 in (660 mm)
F. Track on ground	78 in (1.98 m)	78 in (1.98 m)	78 in (1.98 m)
Area of track on ground	2496 in ² (1.61 m ²)	3120 in ² (2.01 m ²)	4056 in ² (2.62 m ²)
Ground pressure	5.7 psi (39.3 kPa)	4.6 psi (31.7 kPa)	3.7 psi (25.5 kPa)
DIMENSIONS			
G. Height to top of ROPS	8 ft 5.8 in (2.58 m)	8 ft 5.8 in (2.58 m)	8 ft 6.6 in (2.61 m)
H. Ground clearance w/drawbar	13.9 in (353 mm)	13.9 in (353 mm)	13.9 in (353 mm)
Turning clearance circle, brake turn	20 ft 6 in (6.25 m)	20 ft 6 in (6.25 m)	20 ft 6 in (6.25 m)
Turning clearance circle, power turn	31 ft 9 in (9.7 m)	31 ft 9 in (9.7 m)	31 ft 9 in (9.7 m)
Length –			
I. Blade straight with drawbar	13 ft 0.3 in (3.97 m)	13 ft 0.3 in (3.97 m)	13 ft 0.3 in (3.97 m)
Blade straight with ripper	14 ft 7.7 in (4.46 m)	16 ft 8 in (5.08 m)	16 ft 8 in (5.08 m)
Blade angled with drawbar	14 ft 7.2 in (4.45 m)	14 ft 10 in (4.52 m)	14 ft 10 in (4.52 m)
Width –			
Blade straight	96 in (2.44 m)	110 in (2.79 m)	110 in (2.79 m)
J. Blade angled	7 ft 5 in (2.26 m)	99.7 in (2.53 m)	99.7 in (2.53 m)
K. Over track	69 in (1.75 m)	84 in (2.13 m)	90 in (2.29 m)

STANDARD EQUIPMENT

OPERATOR'S COMPARTMENT

ROPS/FOPS canopy
Vinyl suspension seat w/back adjustment
Retractable seat belt, 2 in (51 mm)
Adjustable armrests
Foot rests
Tool storage area

ENGINE

Case 4-390 diesel – or – Case 4T-390 turbocharged diesel
Automatic fan belt tensioner
Integral engine oil cooling
Fuel filter
Dual element air cleaner
65 amp alternator
700 CCA 12-volt battery
Engine side panels

POWERTRAIN

4F/4R modulated 2 speed Powershift transmission
Automatic spring-applied parking brake
Oil-cooled power disc brakes

HYDRAULICS

Hydraulic tube guard

BLADE

2 position mechanical pitch adjustment
Single lever control for blade lift, angle and tilt

UNDERCARRIAGE

Hydraulic track adjusters
Case Lubricated Track Chain
Permanently lubricated track and carrier rollers
Track adjuster guard
Track guides (front and rear)

OTHER

Backup alarm
Horn
Anti-vandalism package
Mirror
Pre-cleaner
Lights - 2 front, 2 rear
Rear counterweight (LT only)

OPTIONAL EQUIPMENT

OPERATOR'S COMPARTMENT

ROPS heater
3 in (76 mm) seat belt
Deluxe air suspension seat
Decelerator
In-line shift pattern
ROPS headliner

HYDRAULICS

4 spool hydraulic valve for field- installed ripper

REAR MOUNTED EQUIPMENT

Ripper, 5 slot with 3 shanks

BLADES

96 in (2.44 m) LT
110 in (2.79 m) WT, LGP

GUARDS

Sweeps
Center rockguard
Final drive bottom
Final drive seal
Rear transmission (for WT and LGP)

SCREENS

Rear ROPS
Side ROPS
Radiator brush

OTHER

Counterweight, front
Counterweight, rear
Drawbar
Sprocket, relieved (LT w/ CLT only)
Special paint
Front pull hook
Muffler, spark arresting
Fan, reversible
Anti-sandblast radiator
Case Extended Life Track
Leg cushion pads
Cold start aid

TRACK

LONG TRACK

16 in (406 mm) rubber track
16 in (406 mm) closed grousers and sealed track
16 in (406 mm) closed grousers and CLT
16 in (406 mm) open grousers and CELT

WIDE TRACK

16 in (406 mm) closed grousers and CLT
16 in (406 mm) open grousers and CELT
20 in (508 mm) closed grousers and CLT
20 in (508 mm) open grousers and CELT

LGP

25 in (635 mm) closed grousers and CLT
25 in (635 mm) open grousers and CELT

NOTE: All specifications are stated in accordance with SAE Standards or Recommended Practices, where applicable.

NOTE: All engines meet current EPA emissions requirements.

IMPORTANT: CNH America LLC reserves the right to change these specifications without notice and without incurring any obligation relating to such change. CNH America LLC does not warrant the safety or reliability of attachments from other manufacturers.

Case is a registered trademark of CNH America LLC. Any trademarks referred to herein, in association with goods and/or services of companies other than CNH America LLC, are the property of those respective companies.



www.casece.com

 CASE IS A BRAND OF CNH,
A GLOBAL LEADER IN CONSTRUCTION EQUIPMENT, AGRICULTURAL EQUIPMENT AND FINANCIAL SERVICES.